

Automatic labeller – EC316D



Non-contractual photo

Description

The horizontal labelling machine EC316D is designed for wrap-around labels on all types of round containers such as metal can (up to 5 KG), plastic or glass jars, cardboard, etc.

Our labelling machine saves time and improves productivity. It can apply labels of different sizes (recommended: 3 formats max/ machine). It is easy to operate and can be integrated with other production equipment to form an automated production line.

This machine has the following features:

- a hot melt glue dispenser with digital display setting
- an electric motor
- a membrane pump to regulate the cold glue used to close the label using a product detector
- mechanical label feeder
- containers are driven into the machine using 2 conveyor belts
- certification according to machine directive 2006/42/EC



Automatic labeller – EC316D

Technical characteristics

	Container dimensions				Label dimensions				Power (KW)		Max rate cans/hour
	Ø (mm)		Height (mm)		Length (mm)		Width (mm)		Motor	Resistor	
	Min	Max	Min	Max	Min	Max	Min	Max			
EC316D	76	158	60	300	245	510	52	292	0.75	2	3800*

* depends on working conditions & format

Option

Characteristics	Description
Regulated front pneumatic lifting	Creates a regulated ascent and descent of the labels by pneumatic control.
Chantourneur	Placed at the entrance and/ or the exit of the machine, it places the cans from a vertical to an horizontal position and vice versa.
Reversed entry	The cans will enter from the right to left side of the machine.
Special guides	Used for glass containers.

Dimensions (in mm)

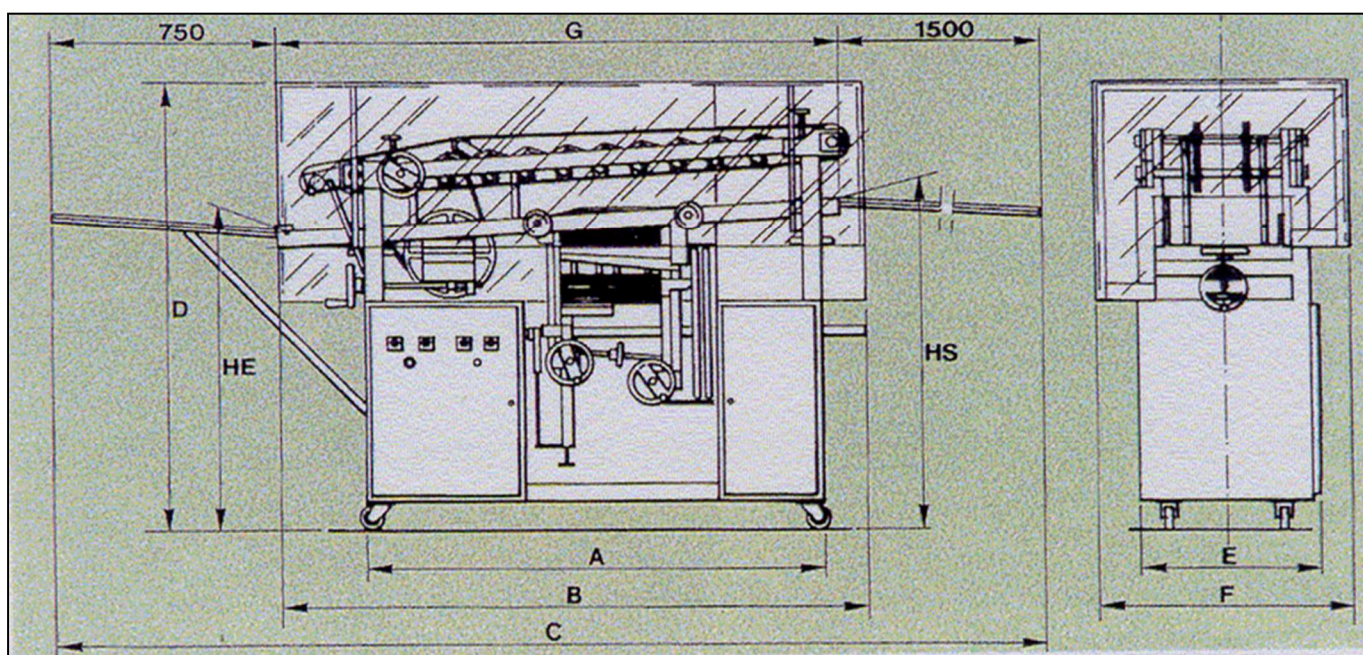

A : 1750mm B : 2240mm C : 4320mm D : 1540mm E : 655mm
 F : 850mm G : 2050mm HE : 1060mm HS : 1100mm
 Net weight: 400 kg Brut weight: 600 kg Shipping size: 2.44x1.12x1.85 m

If you are using conveyors with the chantourneurs, you need to respect :

- a descending slop of 25° between the conveyor and the entry of the machine.
- a descending slop of 25° between the exit of the machine and the conveyor.



AFU SAS
 64 rue de la Ville es Cours, 35400 Saint Malo – FRANCE
 Tel : +33 (0)2 99 82 14 88
 E-mail : contact@duvivier-etiq-conserves.com

www.duvivier-etiq-conserves.com